



VPP46..



VPI46..



VPP46..Q, with pressure test points P/T VPI46..Q, with pressure test points P/T

ACVATIX™

Combi valves, PN 25

VPP46..
VPP46..Q
VPI46..
VPI46..Q

for rooms, zones, ventilation and air-conditioning systems

- With integrated differential pressure controller
- Valve body made of dezincification resistant hot-pressed brass (DZR)
- Volumetric flow 30... 1330 l/h,
- DN 10...DN 20
- Differential pressure range 15...400 kPa
- Internally threaded Rp conforming to ISO 7-1
- Externally threaded G conforming to ISO 228-1
- Version with pressure test points for Δp measurement (optional)
- Can be equipped with actuators
 - SSA.. (3-position or DC 0...10 V)
 - STA.. (2-position or PDM)
 - STS61.. (DC 0...10 V)
 - SFA.. (2-position, with spring-return)
 - SUA.. (2-position, non-spring-return)

Use

- In ventilation and air conditioning plants for control on the water side and automatic hydraulic balancing of terminal units, such as fan coils, induction units, and in heat exchangers for heating or cooling
- In heating zones like self-contained heating systems, apartments, individual rooms, etc.
- For closed circuits

Type summary

Product no.	Stock no.	DN	H ₁₀₀	Connections		Test points	V̇ _{min}	V̇ ₁₀₀	STA.. / STS61.. SFA.. / SUA21..		SSA..	
				[mm]	[inch]				Δp _{min}	Δp _{max}	Δp _{min}	Δp _{max}
VPP46.10L0.2	S55264-V101	10	2.5	G ½	externally threaded	-	30	200	15	400	15	400
VPP46.15L0.2	S55264-V102	15		G ¾			30	200	15	400	15	400
VPP46.15L0.6	S55264-V103	20	5	G 1			100	575	15	400	15	400
VPP46.20F1.4	S55264-V104			220			1330	-	-	20	400	
VPP46.10L0.2Q	S55264-V105	10	2.5	G ½		with pressure test points P/T	30	200	15	400	15	400
VPP46.15L0.2Q	S55264-V106	15		G ¾			30	200	15	400	15	400
VPP46.15L0.6Q	S55264-V107	20	5	G 1			100	575	15	400	15	400
VPP46.20F1.4Q	S55264-V108						220	1330	-	-	20	400
VPI46.15L0.2	S55264-V109	15	2.5	Rp ½	internally threaded	-	30	200	15	400	15	400
VPI46.15L0.6	S55264-V110			Rp ¾			100	575	15	400	15	400
VPI46.20F1.4	S55264-V111	20	5	Rp ¾			220	1330	-	-	20	400
VPI46.15L0.2Q	S55264-V112	15	2.5	Rp ½			30	200	15	400	15	400
VPI46.15L0.6Q	S55264-V113			Rp ¾		100	575	15	400	15	400	
VPI46.20F1.4Q	S55264-V114	20	5	Rp ¾		220	1330	-	-	20	400	

DN = nominal size

H₁₀₀ = nominal stroke

V̇₁₀₀ = volumetric flow through fully open valve (H₁₀₀)

V̇_{min} = smallest pre-settable volumetric flow through fully open valve (H₁₀₀)

Δp_{max} = maximum permissible differential pressure across the valve's control path, valid for the entire actuating range of the motorized valve

Δp_{min} = minimum differential pressure required across the valve's control path, so that the difference pressure regulator works reliably

Fittings

Product no.	Stock no.	Description
ALG..2	ALG..2	Set of 2 fittings with threaded connections for 2-port valves, consisting of 2 union nuts, 2 discs and 2 flat seals. ALG..2B are brass fittings, for media temperatures up to 100 °C.
ALG..2B	S55846-Z1..	

Ordering

Example

Product no.	Stock no.	Designation
VPP46.15L0.2	S55264-V102	Combi valve, PN 25, externally threaded
SSA61	SSA61	Actuator

Delivery Combi valves, actuators and accessories are packed and supplied separately.

Revision numbers See page 12

Equipment combinations

	Actuators	Operating voltage	signal	Positioning time		force	Spring return	Stroke	Connecting cable	Data sheet
				2.5 mm						
DN 10...20: VPP46.. VPI46..	SSA31	AC 230 V	3-position	150 s	60 s/mm	100 N	-	2.5 mm 5 mm	1.5 m	N4893
	SSA81	AC 24 V								
	SSA61	DC 0...10 V	75 s	30 s/mm						
	SSA31/00	AC 230 V	3-position	150 s	60 s/mm					
	SSA81/00	AC 24 V								
	SSA61/00	DC 0...10 V	75 s	30 s/mm						
DN 10...15: VPP46..L.. VPI46..L..	STA21..	AC 230 V	2-position, PDM	180 s	70 s/mm	105 N	✓	2.5 mm	see data sheet	N4877
	STA71..	AC 24 V								N4875
	STA72E..									N4880
	STS61..	DC 0...10 V	75 s	30 s/mm						
	SFA21/18	AC 230 V	2-position	10 s	4 s/mm	200 N	✓	2.5 mm	1.8 m	N4863
	SFA71/18	AC 24 V								
	SUA21/1	AC 230 V	2-position, SPST	10 s	4 s/mm	150 N	-	2.5 mm	1.5 m	N4830

Fittings

Combi valves		Set of fittings		
Externally threaded		Malleable cast iron	Brass	
Product no.	Stock no.	Type / Stock no.	Product no.	Stock no.
VPP46.10L0.2	S55264-V101	-	ALG132 ¹⁾	ALG132
VPP46.15L0.2	S55264-V102	-	ALG142 ¹⁾	ALG142
VPP46.15L0.6	S55264-V103	-	ALG142 ¹⁾	ALG142
VPP46.20F1.4	S55264-V104	ALG152	ALG152B ²⁾	S55846-Z100
VPP46.10L0.2Q	S55264-V105	-	ALG132 ¹⁾	ALG132
VPP46.15L0.2Q	S55264-V106	-	ALG142 ¹⁾	ALG142
VPP46.15L0.6Q	S55264-V107	-	ALG142 ¹⁾	ALG142
VPP46.20F1.4Q	S55264-V108	ALG152	ALG152B ²⁾	S55846-Z100

¹⁾ Connecting thread pipe side: Internally threaded

²⁾ Usable up to maximum medium temperature of 100 °C

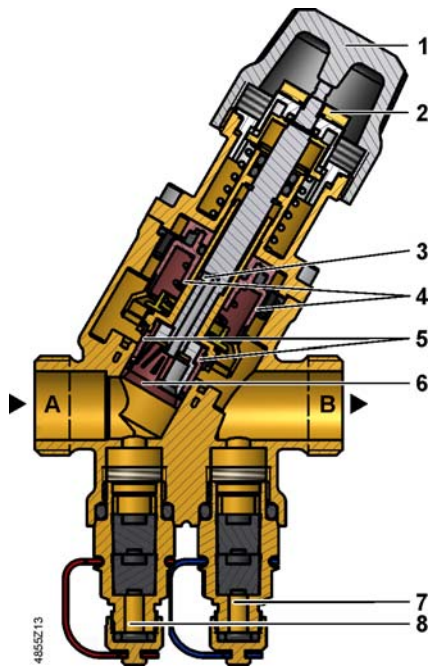

- 1 Manual control knob
- 2 Ring with dial for presetting
- 3 Aperture for differential pressure controller is linked with outlet port B
- 4 Differential pressure controller
- 5 Plug for presetting opening
- 6 Flow control valve
- 7 Pressure test point, blue ribbon, P-
- 8 Pressure test point, red ribbon, P+
- A Inlet port A
- B Outlet port B

Combi valves VP..46..Q (shown here) are additionally equipped with pressure test points P/T.

Functional principle

The medium entering the valve (inlet port A) passes through the variable presetting opening (5) which is connected to the ring with the dial (2) for presetting the desired maximum volumetric flow. Then, the medium flows through the flow control valve (6) with a linear characteristic and a stroke of 2.5 mm (DN 10...15) respectively 5 mm (DN 20).

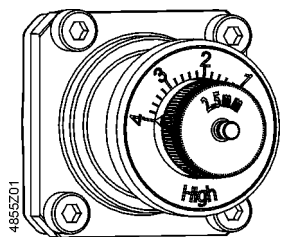

Ring with dial for presetting (2)

The actuator (not shown here) opens and accurately positions the control valve (6). Before leaving the Combi valve, the medium passes through a built-in mechanical differential pressure controller (4). This differential pressure controller is the heart of the Combi valve and ensures that the selected volumetric flow is maintained across the whole working range and independent of the inlet pressure p_1 . The Combi valves VP..46..Q are additionally equipped with two pressure test points (P+, P-), which allow measurement of the differential pressure across the Combi valve. For that purpose, the electronic manometer ALE10 can be used.

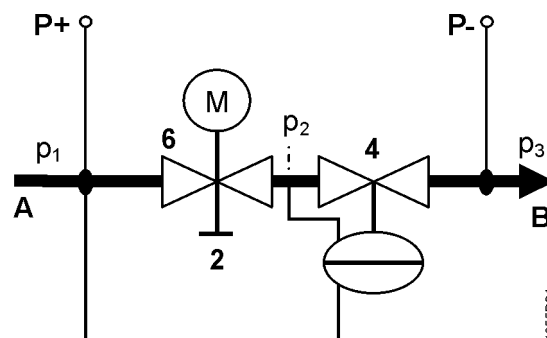

- A Inlet medium (inlet port)
- B Outlet medium (outlet port)
- 2 Ring with dial for presetting
- 4 Differential pressure controller maintains the pressure $p_1 - p_2$ constant across the flow control valve (6) and the presetting (2)
- 6 Control valve with mounted actuator

- P- = P/T port, pressure test point with blue ribbon (7)
- P+ = P/T port, pressure test point with red ribbon (8)
- p_1 = pressure at inlet of Combi valve
- p_2 = pressure at outlet of flow control valve
- p_3 = pressure at outlet of Combi valve

Manual control



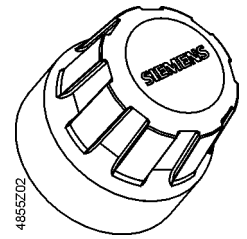





The manual control knob (1) is ready fitted to protect valve stem and pre-set mechanism and facilitates manual control of the Combi valve during commissioning.

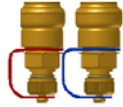

Factory setting:

The valve is closed and needs to be fully open with the manual knob in order to flush the pipe system.

Accessories

Product no.	Stock no.		Description
ALE10	ALE10		Electronic manometer excluding measuring lines and measuring tips. Measuring range 700 kPa, max. 1000 kPa. For measuring the differential pressure between P+ and P- of the Combi valves (refer to diagram under "Functional principle" on page 3). Functions of the manometer: <ul style="list-style-type: none"> • Start/stop • Automatic zero position • Backlit display • Display: Out → outside the measuring range • Holding function
ALE11	ALE11		Measuring lines and straight measuring tips for use with Siemens Combi valves. Equipped with G 1/8" connection with 2 x 40 mm needles.
ALP45	ALP45		P/T ports (set of 2 pieces) Set contains 1 piece each with a red and blue ribbon. Port: External threads G 1/8" to ISO 228 Connection to valve body: G 1/4" to ISO 228, inclusive O-ring
ALP46	S55264-V115		Blanking plugs for P/T ports Connection to valve body: G 1/4" to ISO 228, inclusive O-ring
ALP47	S55264-V116		Drain ball valve inclusive O-ring Port: External threads G 1/2" to ISO 228 Connection to valve body: G 1/4" to ISO 228, inclusive O-ring
ALP48	S55264-V117		Combined P/T port and drain ball valve with red ribbon Port: External threads G 1/8" to ISO 228 Connection to valve body: G 1/4" to ISO 228, inclusive O-ring
ALP49	S55264-V118		Long P/T ports (set of 2 pieces) Set contains 1 piece each with a red and blue ribbon. Port: External threads G 1/8" to ISO 228 Connection to valve body: G 1/4" to ISO 228, inclusive O-ring
ALP50	S55264-V119		Spare black valve protection cap

Engineering example

Basis of calculation

1. Determine energy demand Q [kW]
2. Determine temperature differential ΔT [K]
3. Calculate volumetric flow

$$\dot{V} = \frac{Q[\text{kW}] \cdot 1000}{1.163 \cdot \Delta T[\text{K}]} \left[\frac{\text{l}}{\text{h}} \right]$$
4. Select suitable Combi valve
 - pipe connections (internally or externally threaded)
 - with or without P/T ports
5. Determine dial setting using volumetric flow/dial presetting table, see the following page

Example

1. Given is a heat exchanger with Q = 1.9 kW
2. Temperature differential (supply - return) ΔT = 6 K
3. Volumetric flow

$$\dot{V} = \frac{1.9 \text{ kW} \cdot 1000}{1.163 \cdot 6 \text{ K}} = 272,28 \text{ l/h}$$

Hint: You can also determine the volumetric flow using the valve slide rule.

4. The valve shall have connections with external threads to ISO 228-1 and size DN 15.
5. Combi valve selection:
VPP46.15L0.6 (externally threaded connections, no pressure test points P/T, nominal volumetric flow 600 l/h)
6. Determine dial setting using volumetric flow/dial presetting table below:
Volumetric flow 270 l/h
Dial setting 1.8

Volumetric flow/dial presetting

Tables to determine the dial setting for a desired volumetric flow.

- Presetting range linear to VDI/VDE 2173
- Presetting range linear
- Presetting range not permitted

VPP46.10L0.2, VPP46.10L0.2Q

200 l/h nominal

[l/h]				30	35	40	50	60	70	80	90	100	110	120	130	140	150	160	170	180	190	200
Dial	Min.	0.2	0.4	0.5	0.6	0.8	1	1.2	1.4	1.6	1.8	2	2.2	2.4	2.6	2.8	3	3.2	3.4	3.6	3.8	Max.

VPP46.15L0.2, VPP46.15L0.2Q

200 l/h nominal

[l/h]				30	35	40	50	60	70	80	90	100	110	120	130	140	150	160	170	180	190	200
Dial	Min.	0.2	0.4	0.5	0.6	0.8	1	1.2	1.4	1.6	1.8	2	2.2	2.4	2.6	2.8	3	3.2	3.4	3.6	3.8	Max.

VPP46.15L0.6, VPP46.15L0.6Q

600 l/h nominal

[l/h]				100	115	130	160	180	210	240	270	300	320	350	380	410	440	460	490	520	550	575
Dial	Min.	0.2	0.4	0.5	0.6	0.8	1	1.2	1.4	1.6	1.8	2	2.2	2.4	2.6	2.8	3	3.2	3.4	3.6	3.8	Max.

VPP46.20F1.4, VPP46.20F1.4Q

1400 l/h nominal

[l/h]					220	290	350	420	480	550	610	680	740	810	870	940	1000	1070	1130	1200	1260	1330
Dial	Min.	0.2	0.4	0.5	0.6	0.8	1	1.2	1.4	1.6	1.8	2	2.2	2.4	2.6	2.8	3	3.2	3.4	3.6	3.8	Max.

VPI46.15L0.2, VPI46.15L0.2Q

200 l/h nominal

[l/h]				30	35	40	50	60	70	80	90	100	110	120	130	140	150	160	170	180	190	200
Dial	Min.	0.2	0.4	0.5	0.6	0.8	1	1.2	1.4	1.6	1.8	2	2.2	2.4	2.6	2.8	3	3.2	3.4	3.6	3.8	Max.

VPI46.15L0.6, VPI46.15L0.6Q

600 l/h nominal

[l/h]				100	115	130	160	180	210	240	270	300	320	350	380	410	440	460	490	520	550	575
Dial	Min.	0.2	0.4	0.5	0.6	0.8	1	1.2	1.4	1.6	1.8	2	2.2	2.4	2.6	2.8	3	3.2	3.4	3.6	3.8	Max.

VPI46.20F1.4, VPI46.20F1.4Q

1400 l/h nominal

[l/h]					220	290	350	420	480	550	610	680	740	810	870	940	1000	1070	1130	1200	1260	1330
Dial	Min.	0.2	0.4	0.5	0.6	0.8	1	1.2	1.4	1.6	1.8	2	2.2	2.4	2.6	2.8	3	3.2	3.4	3.6	3.8	Max.

Engineering notes

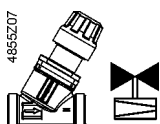
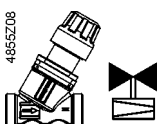
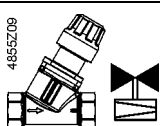
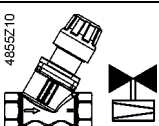
Valve	Symbols / Direction of flow		Flow in control mode		Valve stem	
	VP..46..	VP..46..Q	Inlet	Outlet	retracts	extends
Combi valve VPP46..			variable	variable	opens	closes
Combi valve VPI46..			variable	variable	opens	closes



The direction of flow indicated (arrow on the valve body) is mandatory!

The valves should preferably be mounted in the return pipe where temperatures are lower and where the sealing gland is less affected by strain.

Symbols

Symbol used in catalogs and application descriptions	Symbol used in diagrams
	There are no standard symbols for Combi valves in diagrams.

Recommendation

A strainer or dirt trap should be fitted upstream of the valve to enhance reliability. Remove dirt, welding beads etc. from valves and pipes. Do not insulate the actuator bracket, as air circulation must be ensured!

Mounting notes

Combi valve and actuator can be straightforwardly assembled on site. Special tools or adjustments are not required.

Prior to mounting the actuator, the required volumetric flow must be set.

The valve is supplied complete with Mounting Instructions (74 319 0649 0).

Mounting positions

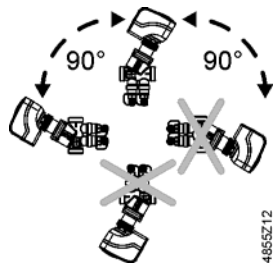

Installation notes

Presetting

Prior to mounting the actuator, the presetting is to be made as follows:

1. Remove control knob from Combi valve.

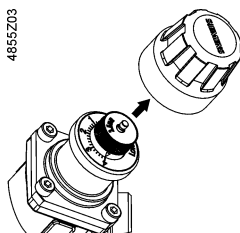

2. Loosen knurled nut.

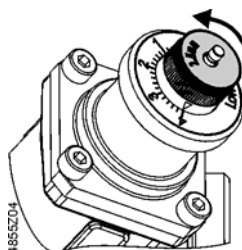

3. Adjust the desired dial setting with the white knob.

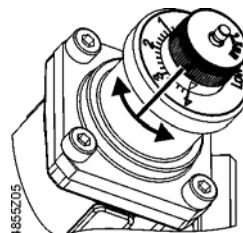

4. Retighten knurled nut by hand.

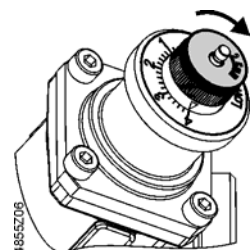

Valve characteristic

VP..46.., VP..46..Q

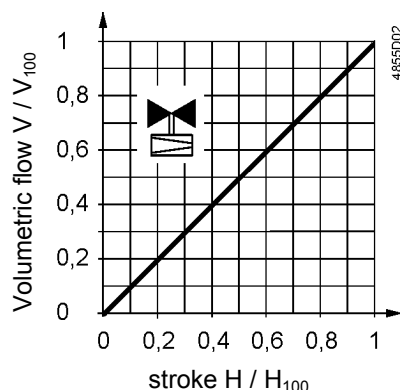

Commissioning notes



The valves must be commissioned with the manual control knob or actuator correctly fitted. Strong pressure impacts can damage closed Combi valves.



The Combi valves have to be open when flushing or pressure testing the system. Strong pressure impacts can damage closed Combi valves.



Differential pressure Δp_{\max} across the valve's control path is not allowed to exceed 400 kPa.

Manual control

When turning the manual control knob in counter-clockwise direction or manually operating the actuator, the valve opens. The actuator closes the valve. The valves are supplied fully open. The manual knob is not designed for permanent manual operation.

Maintenance notes

The V..P46.. Combi valves are maintenance-free.



When performing service work on the valve and / or actuator:

- Switch off the pump and disconnect power supply.
- Close the shut-off valves in the piping network.
- Fully reduce pressure in the piping network and allow the pipes to cool down completely.

Remove the electrical connections only if necessary.

Sealing gland

The stem sealing gland cannot be exchanged. Should leakage occur, the whole valve must be replaced.

Disposal



Due to the different types of material used, the valve must be disassembled prior to disposal. Special handling of certain valve components may be required by law or may be sensible from an ecological point of view.

Local and currently valid legislation must be observed.

Warranty

Application-related technical data are guaranteed only when the valves are used in connection with the Siemens actuators listed under "Equipment combinations" on page 3. When used with actuators of other manufacture, any warranty by Siemens becomes void.

Technical data

Functional data	PN class	PN 25 as per EN 1333
	Permissible operating pressure	2.500 kPa (25 bar) as per ISO 7628 / EN 1333
	Differential pressure control range	
	DN 10 ... DN 15	15...400 kPa
	DN 20	20...400 kPa
	Valve characteristic	Linear as per VDI/VDE 2173 or Linear
	Leakage rate	DN 10...DN 20 Class IV (0...0.01% of volumetric flow V_{100}) to EN 1349
	Permissible media	Low-temperature hot water, chilled water, water with antifreeze Recommendation: Water treatment to VDI 2035
	Medium temperature:	
	Valve with actuator	1...110 °C
	Permissible ambient temperature	1...50 °C
Nominal stroke	DN 10...DN 15 2.5 mm DN 20 5 mm	
Standards	Pressure Equipment Directive	PED 97/23/EC
	Pressure Accessories	As per article 1, section 2.1.4
	Fluid group 2 DN 10...DN 20	Without CE-marking as per article 3, section 3 (sound engineering practice)
	Environmental compatibility	ISO 14001 (Environment) ISO 9001 (Quality) SN 36350 (Environmentally compatible products) RL 2002/95/EG (RoHS)
Materials	Valve body, port, seat, sealing gland and test points	Dezincification resistant hot-pressed brass (DZR), CW602N
	Stem, spring	Stainless steel
	Presetting element	PTFE, PPO, POM C and ABS
	Regulator	PPS
	Seals	EPDM 281 (O-ring)
Dimensions / weight	Dimensions	Refer to "Dimensions" on page 11
	Threaded connections	VPP46.. G to ISO 228-1 (externally threaded) VPI46.. Rp to ISO 7-1 (internally threaded)
	Actuator connection	M30 x 1.5 mm
	Pressure test points (P/T-ports)	G 1/4" (connection valve body) 2 mm x 40 mm (needles)
	Weight	Refer to "Dimensions" on page 11

Application examples

Combi valves in HVAC systems combined with variable speed pumps provide even higher energy efficiency. When sizing the pump, it must be made certain that the most critical branch or consumer in the system – usually the remotest from the pump – gets enough pressure (pump head). Thus, it is recommended to use a variable speed pump in constant-pressure mode with end-point feedback, to maintain a minimum differential pressure across the critical valve.

Residential buildings

Residential buildings with for example self-contained flat heating systems:

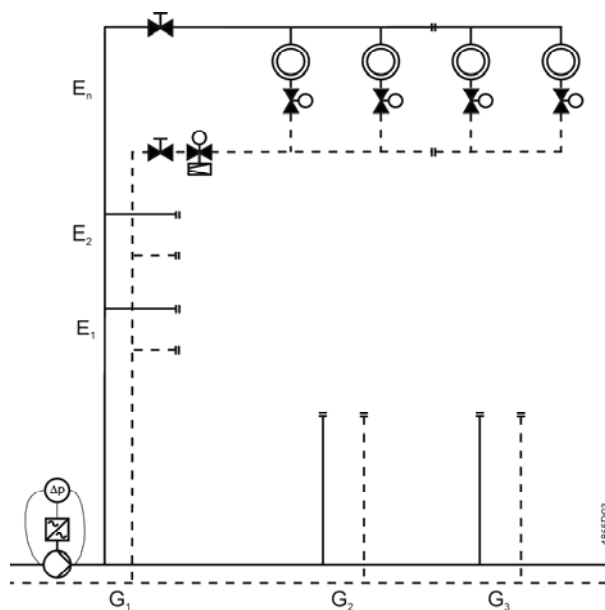

E = Floor
G = Group or zone

Non-residential buildings

Commercial buildings with for example Fan Coil Units or heat exchangers for heating or cooling:

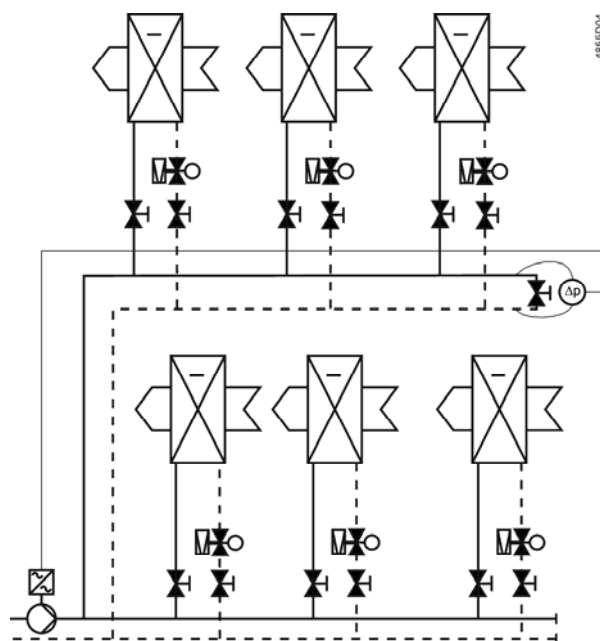

Dimensions

VPP46..

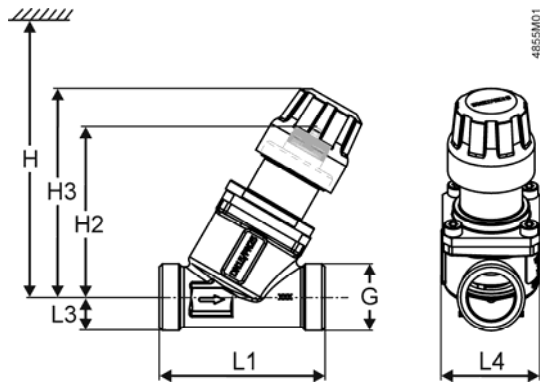

VPP46..Q

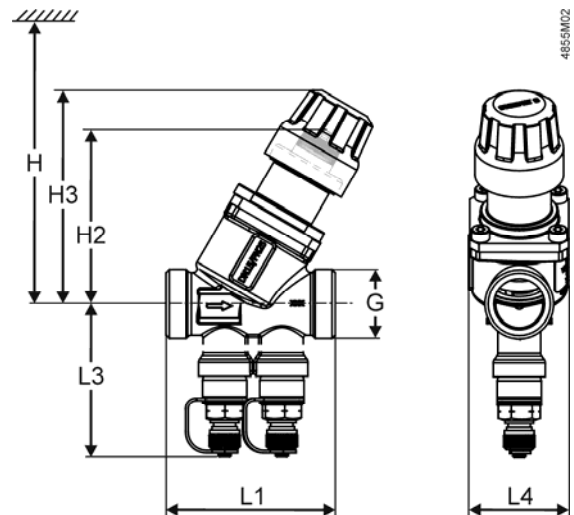

Valves	DN	G	L1	L3	L4	H2	H3	H ¹⁾				Weight
								SSA..	STA../STS61..	SFA..	SUA..	
		[inch]	[mm]	[mm]	[mm]	[mm]	[mm]	[mm]	[mm]	[mm]	[mm]	[kg]
VPP46.10L0.2	10	½	65	10.5	38	68.5	83.5	155	140	175	155	0.329
VPP46.15L0.2	15	¾	65	13.2	38	67.3	82.2	170	155	190	170	0.348
VPP46.15L0.6	15	¾	65	13.2	38	67.3	82.2	170	155	190	170	0.348
VPP46.20F1.4	20	1	70	13.6	38	67.5	82.5	170	155	190	170	0.386
VPP46.10L0.2Q	10	½	65	54.8	38	68.5	83.5	200	185	220	200	0.429
VPP46.15L0.2Q	15	¾	65	55.5	38	67.3	82.2	215	200	235	215	0.429
VPP46.15L0.6Q	15	¾	65	55.5	38	67.3	82.2	215	200	235	215	0.429
VPP46.20F1.4Q	20	1	70	57.3	38	67.5	82.5	215	200	235	215	0.486

¹⁾ Total height including actuator

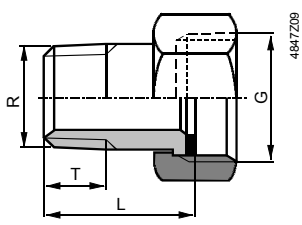
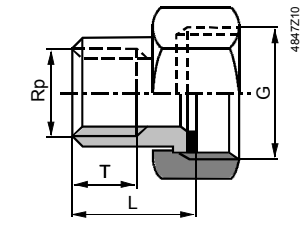
Sets of threaded fittings with flat seal			
ALG...2: set of 2 threaded fittings	ALG132 ALG142	pipe side with external R threads	
	ALG152 ALG152B	pipe side with internal Rp threads	

Type ALG..	for valve type	DN	G	R	Rp	L	T
Malleable cast iron	Brass ¹⁾		[Inch]	[Inch]	[Inch]	[mm]	[mm]
	ALG132	VPP46.10..	10	G ½	R ¾	≈ 24	≈ 9
	ALG142	VPP46.15..	15	G ¾	R 1½	≈ 29.5	≈ 12
ALG152	ALG152B	VPP46.20..	20	G 1	Rp ½	≈ 23	≈ 13

¹⁾ Maximum medium temperature 100 °C

- On valve side: cylindrical thread to ISO 228-1, on pipe side: with cylindrical thread to ISO 7-1

VPI46..

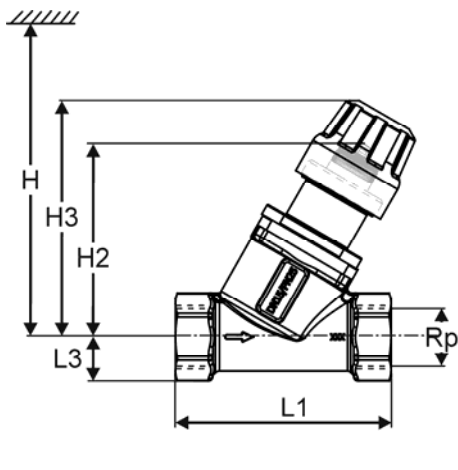

VPI46..Q

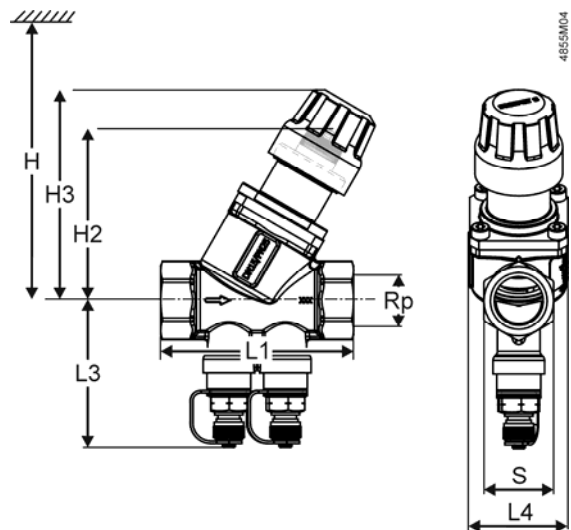

Valves	DN	Rp	S	L1	L3	L4	H2	H3	H ¹⁾				Weight
									SSA..	STA../STS61..	SFA..	SUA..	
		[inch]	[mm]	[mm]	[mm]	[mm]	[mm]	[mm]	[mm]	[mm]	[mm]	[mm]	[kg]
VPI46.15L0.2	15	½	27	75	15.2	38	67.3	82.4	170	155	190	170	0.392
VPI46.15L0.6	15	½	27	75	15.2	38	67.3	82.4	170	155	190	170	0.392
VPI46.20F1.4	20	¾	32	79	17.9	38	67.5	82.5	170	155	190	170	0.433
VPI46.15L0.2Q	15	½	27	75	60.2	38	67.3	82.4	215	200	235	215	0.504
VPI46.15L0.6Q	15	½	27	75	60.2	38	67.3	82.4	215	200	235	215	0.504
VPI46.20F1.4Q	20	¾	32	79	62.9	38	67.5	82.5	215	200	235	215	0.533

¹⁾ Total height including actuator

Revision Numbers

Product number	Valid from rev. no.	Product number	Valid from rev. no.
VPP46.10L0.2	..A	VPP46.10L0.2Q	..A
VPP46.15L0.2	..A	VPP46.15L0.2Q	..A
VPP46.15L0.6	..A	VPP46.15L0.6Q	..A
VPP46.20F1.4	..A	VPP46.20F1.4Q	..A
VPI46.15L0.2	..A	VPI46.15L0.2Q	..A
VPI46.15L0.6	..A	VPI46.15L0.6Q	..A
VPI46.20F1.4	..A	VPI46.20F1.4Q	..A